

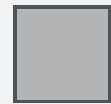

Klapstoel

GEREEDSCHAP:

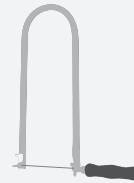

NAAM:

GROEP/KLAS:

INHOUD

AFMETINGEN:

ONDERDELEN:

4 houten latten

OK✓

460 x 30 x 18 mm

2 x C, 2 x D

4 houten latten

300 x 30 x 18 mm

2 x A, 2 x B

4 houten latten

380 x 40 x 15 mm

2 x F, 2 x E

2 houten latten

380 x 20 x 15 mm

G, H

1 houten lat

304 x 20 x 15 mm

J

1 houten lat

268 x 20 x 15 mm

K

1 rondhoutje

325 x Ø 10 mm

greep

1 rondhoutje

160 x Ø 8 mm

scharnier

16 schroeven

3,5 x 25 mm

1 Overzicht:

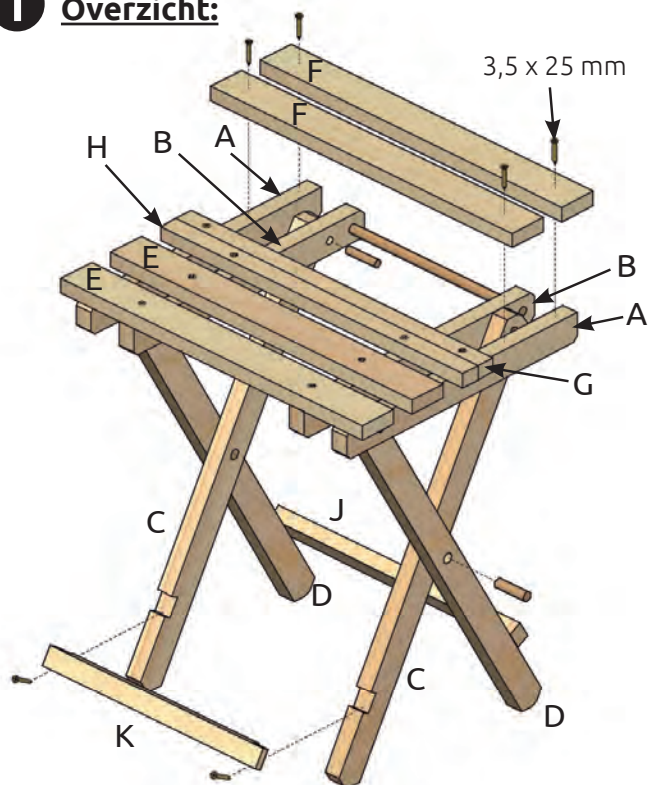

Vershaf jezelf een eerste overzicht.



2 Maten overbrengen:

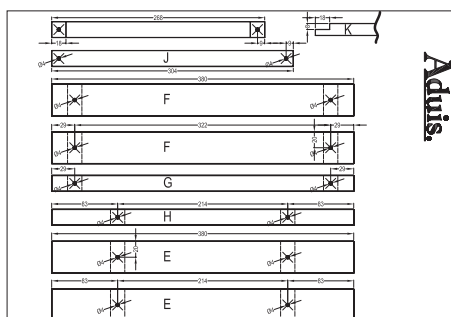
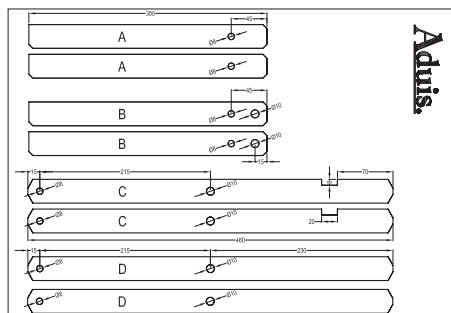

Beschrijf alle latten met de juiste hoofdletter.

Breng alle afmetingen van de gaten, schuine zijden en uitsparingen volgens de gegevens of het sjabloon over op de houten latten.

Teken ook de uitsparingen op de delen (C) en (K).



3 Het zitvlak:

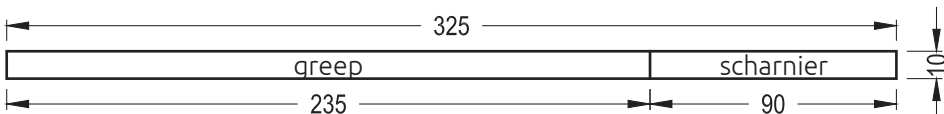
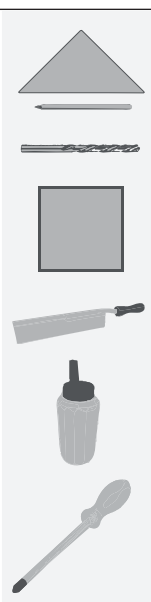
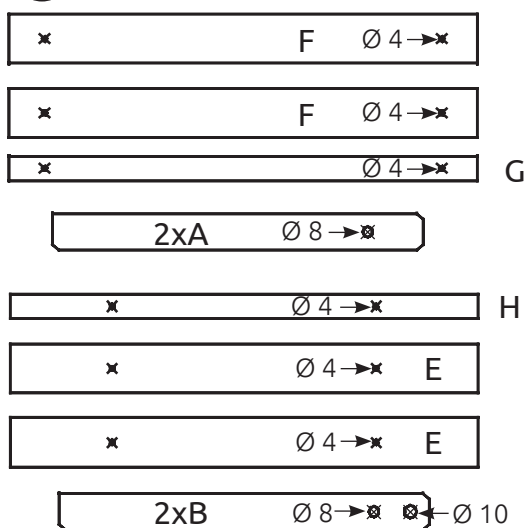

Boor de gaten zoals **aangegeven of volgens het bestek**.

Zaag de delen (A) en (B) met de **toffelzaag** schuin af.

Zaag van het rondhoutje Ø 10 mm een stuk met een lengte van 235 mm af.

Schuur **alle randen en vlakken** met schuurpapier na.

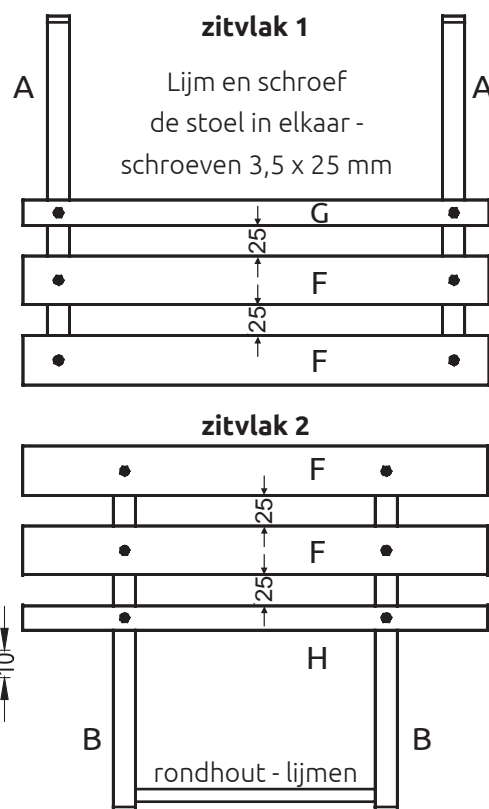

4 De stoelpoten:

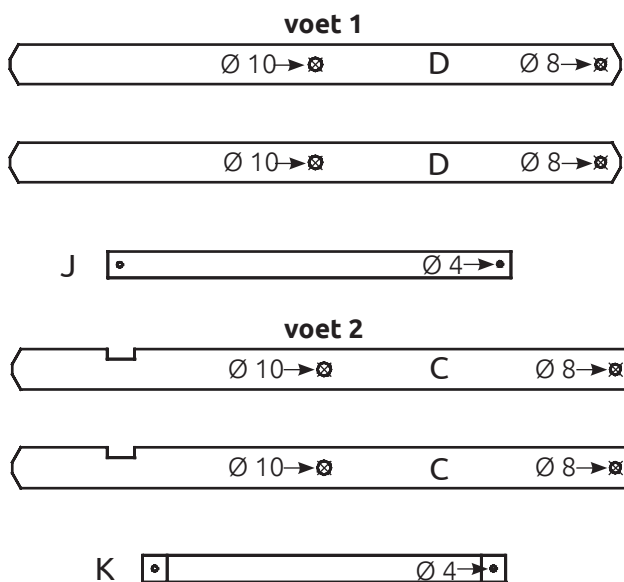
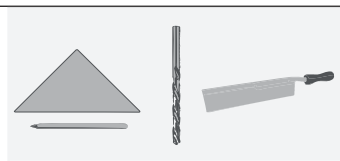

Boor de **gaten** in de delen (C, D, J, K).
 Zaag de delen (C, D) met de figuurzaag af.



5 De stoelpoten (2):

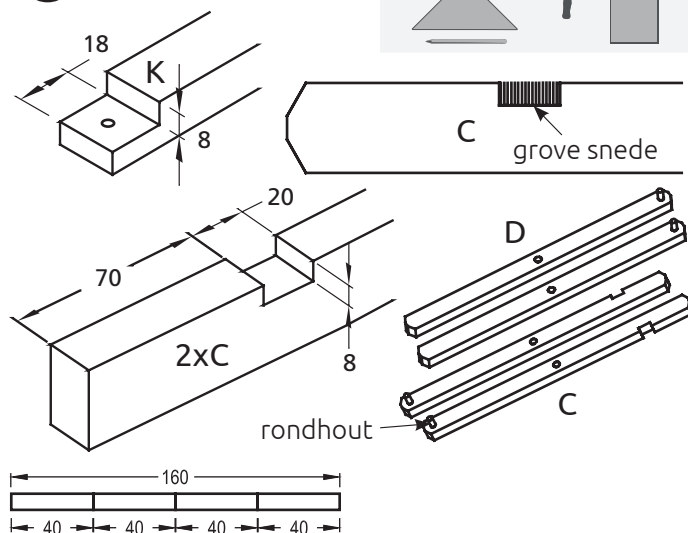
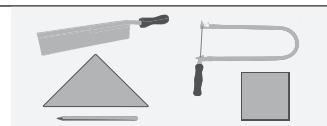

Zaag de **uitsparingen** aan beide zijden in deel (K).
 Maak de uitsparingen in de delen (C), door grove sneden met een **afstand van ca. 1 mm** te zagen en deze met een beitel uit te werken of met een figuurzaag weg te zagen.
 Werk alle randen en vlakken met **schuurpapier** na.
 Zaag 4 delen van het rondhoutje Ø 8 mm af en lijm deze in de delen (C, D).



6 De stoelpoten (3):

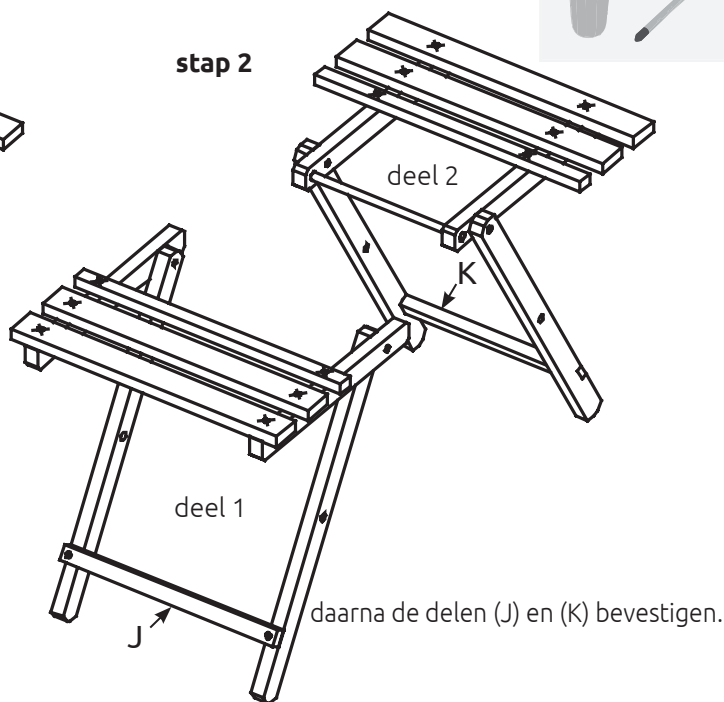
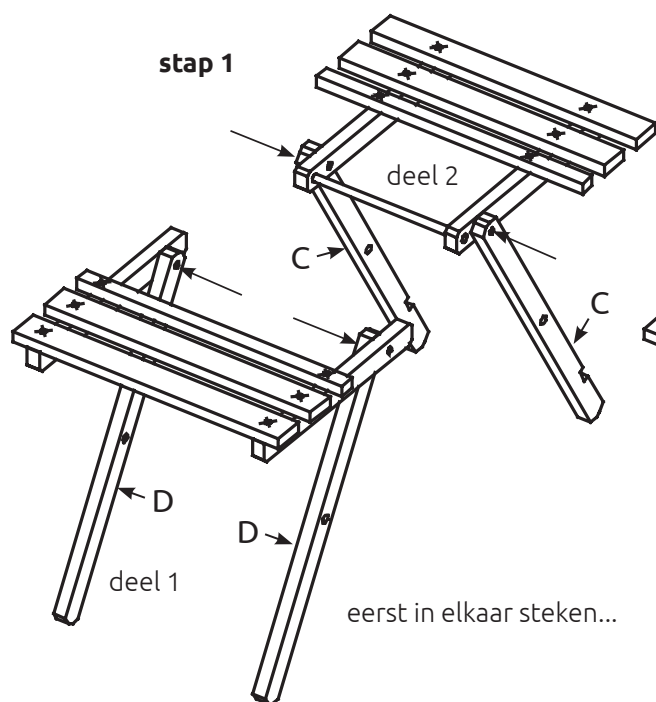

Steek de delen (C) en (B) c.q. (D) en (A) in elkaar - **niet lijmen!**
 Lijm en schroef de latten (K) en (J) vast.



7 Afwerking:

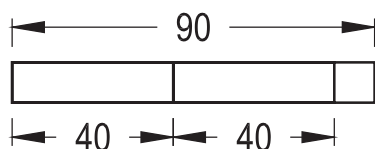
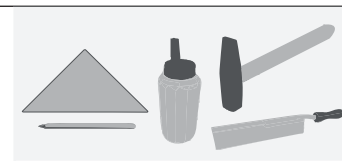

Zaag van het resterende stuk rondhout \varnothing 10 mm

2 stukken met een lengte van 40 mm af.

Steek de 2 delen van de klapstoel in elkaar en verbind ze met de **2 rondhoutjes \varnothing 10 mm**.

Lijm de rondhoutjes alleen in de delen (D) = voet 2 vast!

 **Let op!** Maar een kleine druppel lijm op het rondhoutje aanbrengen.

Sla de 2 rondhoutjes met een hamer in.



OK✓

8 Het oppervlak:



Werk vervolgens nogmaals **alle randen en vlakken** met schuurpapier na.

Let vooral op de **uitstekende delen** van de rondhoutjes.
-> Schuur deze zo glad en vlak mogelijk.

VEEL PLEZIER EN SUCCES!

Let op! De klapstoel is geen trapje - dat wil zeggen niet op de stoel gaan staan maar zitten.

OK✓



Aduis.

Alle latten met doorsnede van 18 x 30 mm

Ontwerp 1 M 1:2

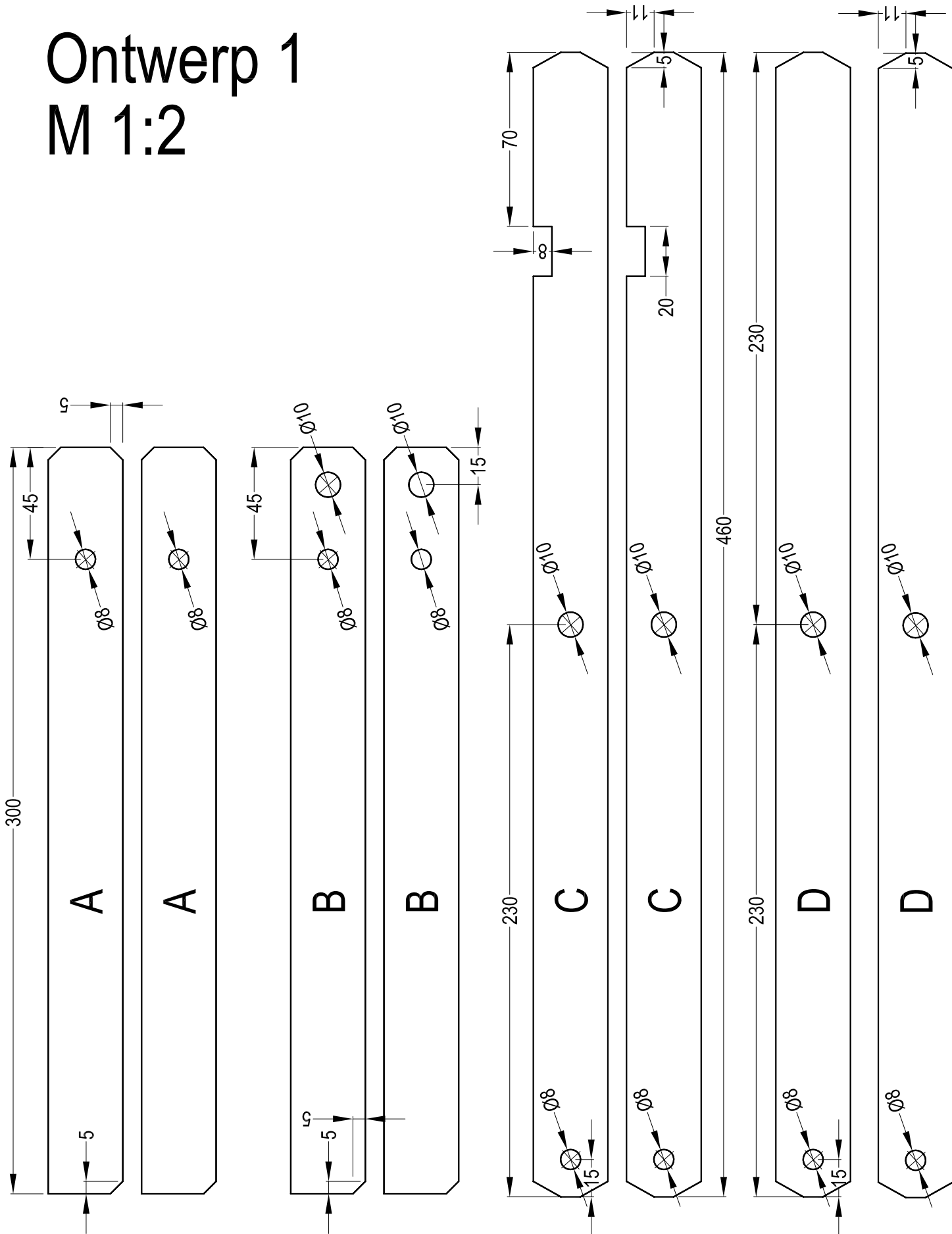

Aduis.

Ontwerp 2 M 1:2

Alle latten met een dikte van 15 mm

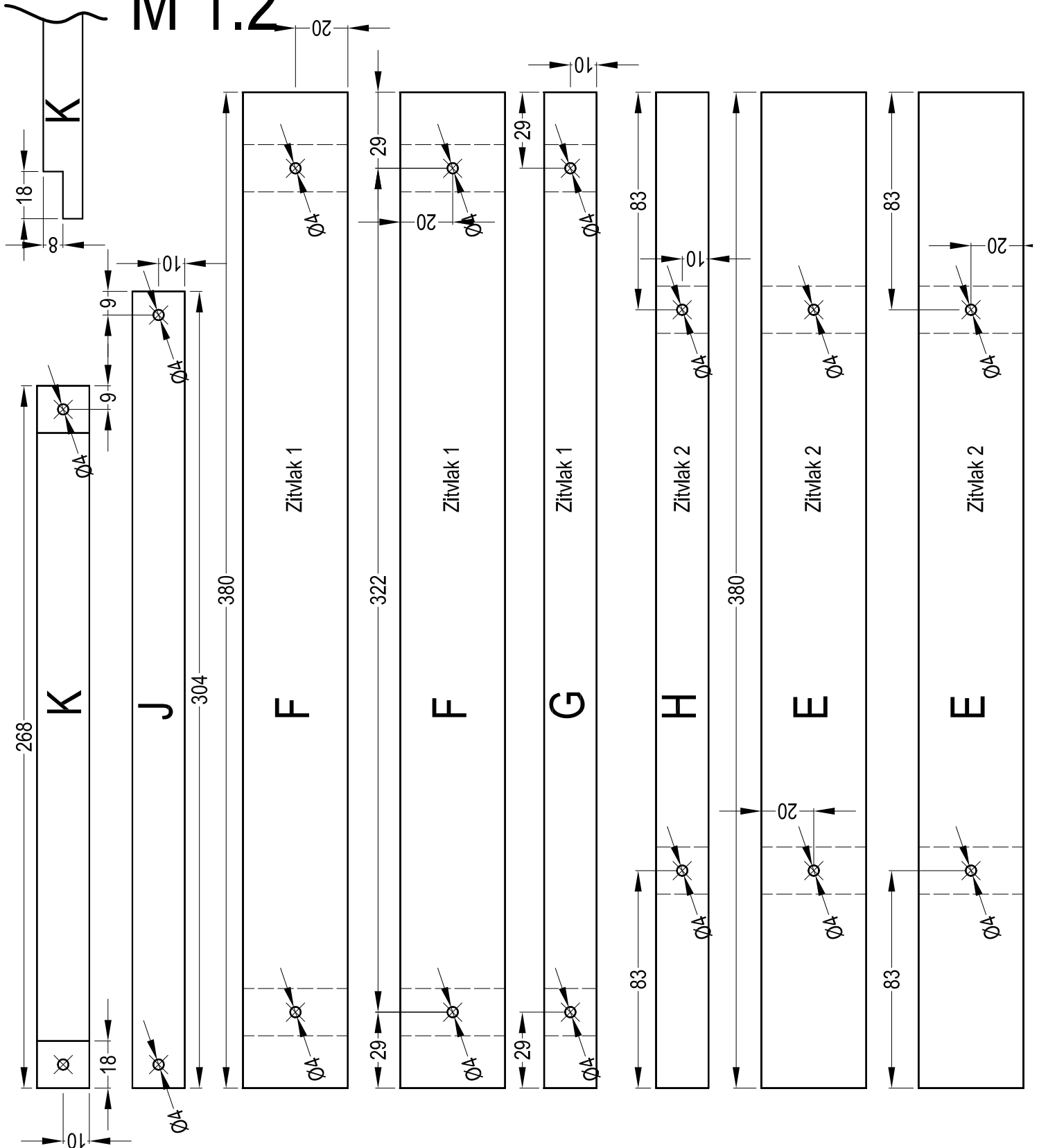

Ontwerp 3

M 1:4

Aduis.

